



Section 1

General Description

The TDM is a multipurpose timing module that can be used for a variety of applications. Its unique design and open architecture allows the TDM to be used in any application that requires timing control of up to two outputs with up to four inputs. Common applications include: simple time delay, vestibule door sequencing (only one device required) and electric lock/automatic door operator sequencing.

The four inputs on the TDM allow sequencing or independent operation of the two outputs. Input 1 will sequence Outputs 1 then 2. Input 2 will sequence Outputs 2 then 1. Input 3 will operate Output 1 independently. Input 4 will operate Output 2 independently.

Both outputs on the TDM are fully programmable for "on time" duration as well as the delay time between the two outputs from 0 to 99 seconds.



WARNING: Devices to be controlled by the TDM must be low voltage (12-24V) but can be inductive loads. Surge suppressors are standard on the TDM.

WET/DRY CONTACT OPTION:

The TDM has the option to supply power to Relay Output 1 contacts. This is known as having a "Wet" contact instead of the conventional "Dry" contact closure. To use output 1 as a "Wet" contact, change the jumper setting (see Figure 1). The voltage supplied to Output 1 will be the same as the voltage supplied to the input power wires of the TDM.



WARNING: Changing jumper settings to enable the "Wet" Contact option will apply a voltage to the Output 1 relay contact. Please ensure that any device connected to this output is capable of accepting voltage. Failure to do so may result in damage to the device.

Section 2

Basic Installation

- 1. Mount the TDM in desired location.
2. With power off, make all necessary wiring connections to the wiring harnesses (Fig. 1).

Figure 1: TDM Layout and Wiring Connections

Detailed wiring and programming instructions for three common applications are included.

Figure 2: Simple Time Delayed Output

Figure 3: Electric Lock & Door Operator Sequencing

Figure 4: Vestibule Door Sequencing

Detailed Operating Display functions for the TDM are shown in Figure 5. For additional technical assistance, contact us toll free at 1-317-842-2545.

Figure 5: TDM Operating Display Function



NOTICE: These instructions are provided for your convenience. Please verify your installation is in compliance with all applicable standards upon completing installation of this device.

Section 3

Technical Data

Table with 2 columns: Parameter and Value. Includes Model, Input Power, Power Consumption, Output Contacts, Relay Contact Rating, Temperature Rating, Weight, and Physical Size.

Section 4

Warranty

MS SEDCO guarantees this product to be free from manufacturing defects for 1 year from date of installation. Unless MS SEDCO is notified of the date of installation, the warranty will be in effect for 1 year from the date of shipment from our factory. If, during the first year, this device fails to operate and has not been tampered with or abused, the unit can be returned prepaid to factory and it will be repaired free of charge. After 1 year, the unit will be repaired for a nominal service charge. This limited warranty is in lieu of all other warranties expressed or implied, including any implied warranty of merchantability, and no representative or person is authorized to assume for MS SEDCO any other liability in connection with the sale of our products. All warranties are limited to the duration of this written warranty. In no event shall MS SEDCO be liable for any special, incidental, consequential or other damages arising from any claimed breach of warranty as to its products or services.

Questions? Call us toll-free at 1-317-842-2545 or visit us online at www.mssedco.com.



FIGURE 1—TDM Layout & Wiring Connections

Input Actions

Input 1—Sequences Output 1 then Output 2
 Input 2—Sequences Output 2 then Output 1
 Input 3—Operates Output 1 only
 Input 4—Operates Output 2 only

Input Connections

Green — Input Power 12-24V (AC or DC)
 Green —
 Blue — Switch Input #1
 Wht/Blue —
 Wht/Red — Switch Input #2
 Wht/Grn —
 Wht/Vio — Switch Input #3
 Wht/Gray —
 Wht/Brown — Switch Input #4

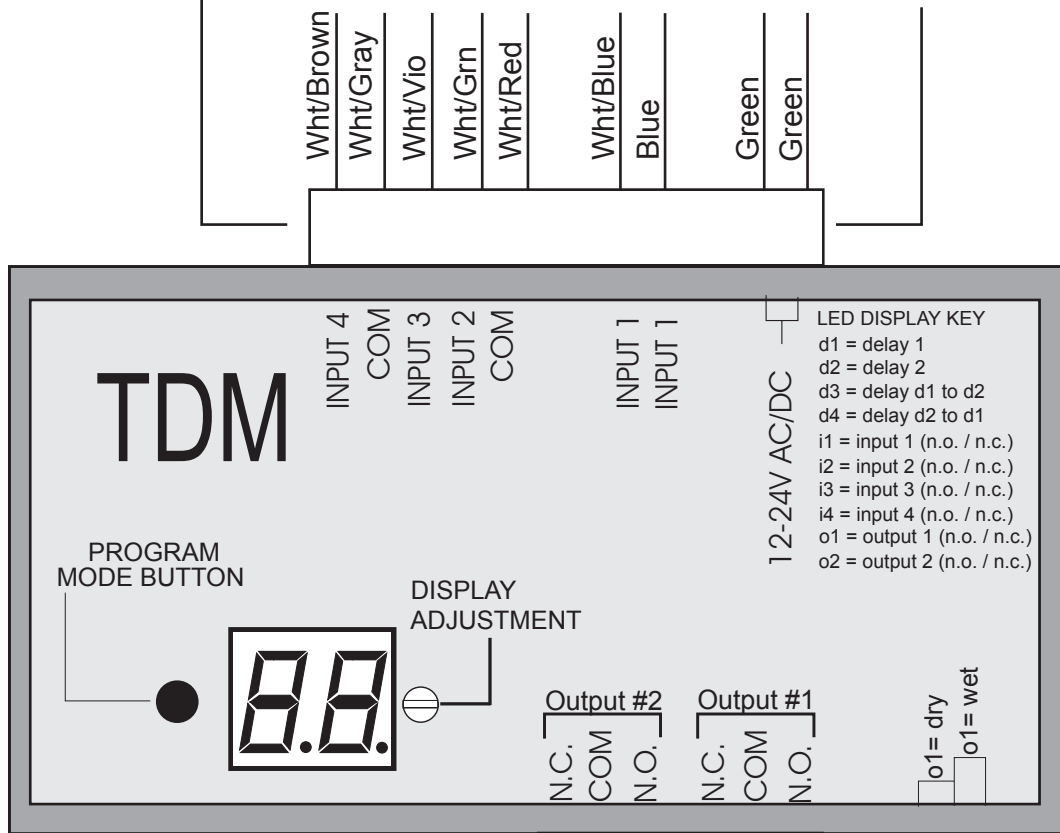

Output Connections

White — N.O. —> Output #1
 Gray — COM —>
 Violet — N.C. —>
 Yellow — N.O. —> Output #2
 Brown — COM —>
 Orange — N.C. —>

Orange
 Brown
 Yellow
 Violet
 Gray
 White

Wet/Dry Contact Option
 (Factory Setting = Dry Contact)

FIGURE 2—Simple Time Delayed Output

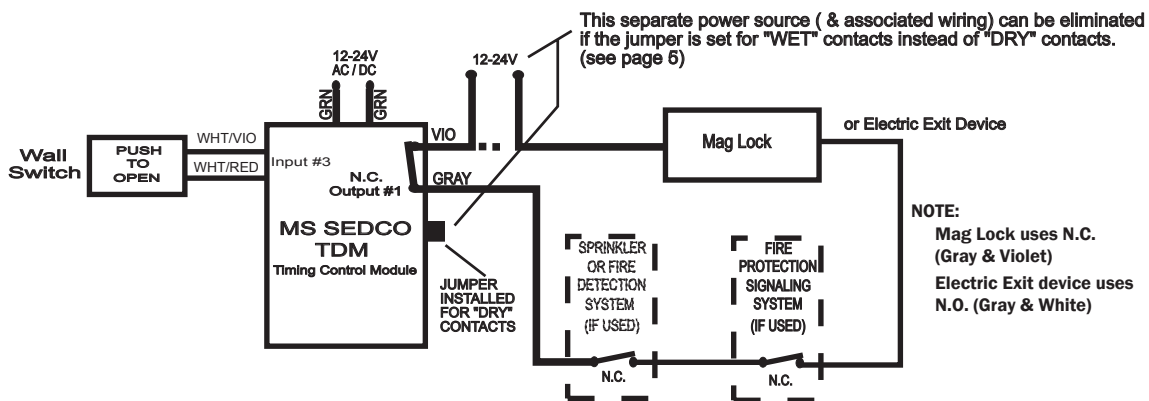

PROGRAMMING PROCEDURE

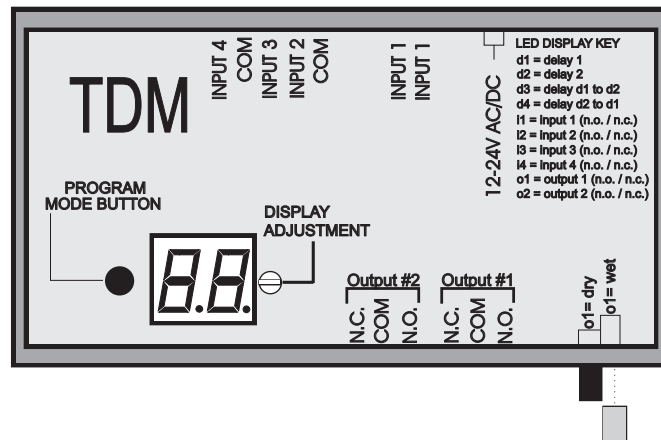

Once the TDM has been wired for the above application, programming of the device is as follows:

- 1) Apply power to the unit, provided there is no smoke or fire, you can assume that your wiring job must be somewhat successful.
- 2) Once properly powered, the display will flash double bars (--) indicating that the unit is in its normal operating ready mode.
- 3) To begin programming, depress the **PROGRAM MODE BUTTON** one time. The first parameter to be programmed will appear on the display. This is the delay time, or "on time" of the output #1 and is displayed as **d1** followed by the time setting (It will flash between the two). To adjust the time setting, use a small screwdriver and rotate the **DISPLAY ADJUSTMENT** clockwise to increase and counterclockwise to decrease the time setting. After the desired value is displayed, depress the **PROGRAM MODE BUTTON** again to save the value. The display will now read **d2**. Now wait 30 seconds until the display again reads double bars (--) indicating that the unit is in its normal operating ready mode.
- 4) You are now ready to test your installation. If the time delay has to be changed, make the change to the **d1** setting, press the **PROGRAM MODE BUTTON** once and then wait 30 seconds until the double bars (--) appear again.
- 5) During operation of the unit, the display will indicate its operating status. Please refer to Figure 5 at the end of this installation manual.

FIGURE 3—Electric Lock and Door Operator

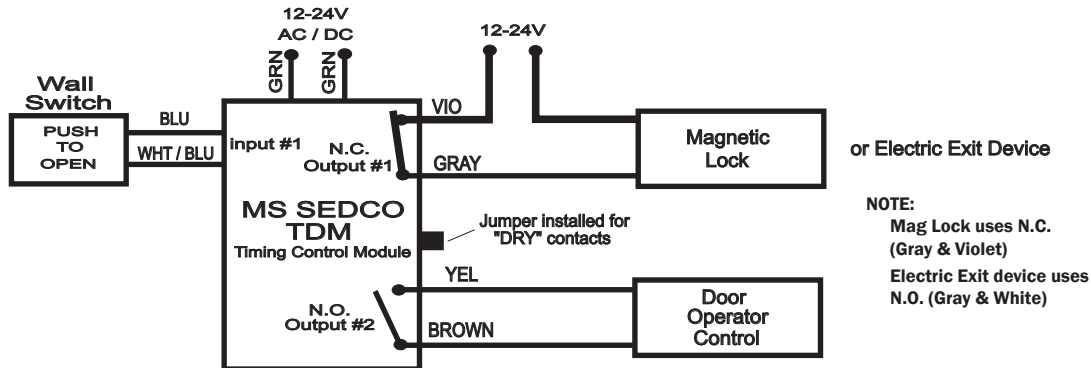

PROGRAMMING PROCEDURE

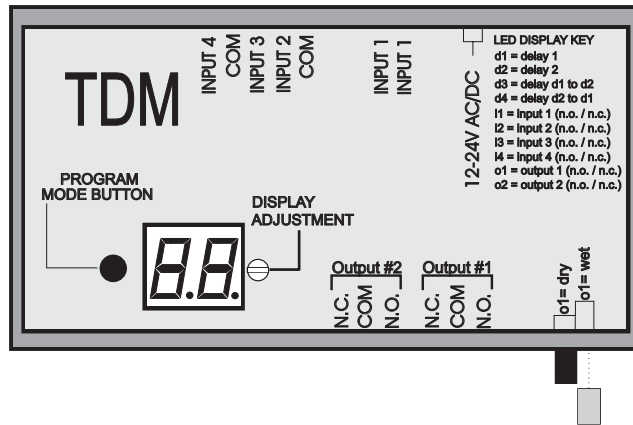

Once the TDM has been wired for the above application, programming of the device is as follows:

- 1) Apply power to the unit. The display will flash double bars (--) indicating that the unit is in its normal operating ready mode.
- 2) To begin programming, depress the **PROGRAM MODE BUTTON** one time. The first parameter to be programmed will appear on the display. This is the delay time, or "on time" of the output #1 and is displayed as **d1** followed by the time setting of **2.0** (Factory Setting) which indicates 2.0 seconds (It will flash between the two). This is the time duration that you want the Electric Lock released (It's usually set around 2-3 seconds). To adjust the time setting, use a small screwdriver and rotate the **DISPLAY ADJUSTMENT** clockwise to increase and counterclockwise to decrease the time setting. After the desired value is displayed, depress the **PROGRAM MODE BUTTON** again to save the value. The display will now read **d2**. **d2** is the delay time or "on time" of output #2. This is the time setting that you want for the door (operator) to remain open. This is usually set around 3-5 seconds. To adjust the setting, rotate the **DISPLAY ADJUSTMENT** until the desired value is displayed and then depress the **PROGRAM MODE BUTTON**. The display should then read **d3**. This is the setting for the delay time between the release of the Electric Lock and the opening of the door. This time is usually set around 0.5-1 second. Again, adjust the setting and then depress the **PROGRAM MODE BUTTON**. The display should now read **d4**. Now wait 30 seconds until the double bars (--) appear, indicating that the unit is in its normal operating ready mode. ***NOTE: d1 should be longer than d3.**
- 3) You are now ready to test your installation. If any of the time settings need to be changed, make the change and press the **PROGRAM MODE BUTTON** once to save the new value. Then wait 30 seconds until the double bars (--) appear again, indicating that the unit is in its normal operating mode.
- 4) During operation of the unit, the display will indicate its operating status. Please refer to Figure 5 at the end of this installation manual.

FIGURE 4—Vestibule Sequencing

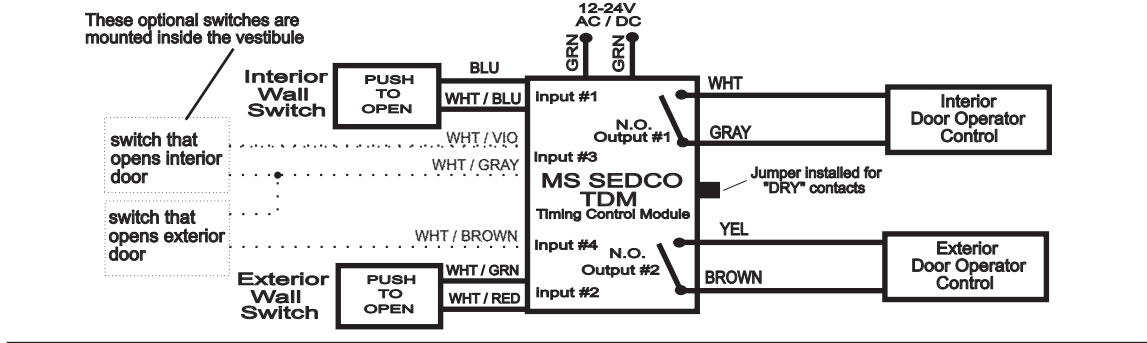

PROGRAMMING PROCEDURE

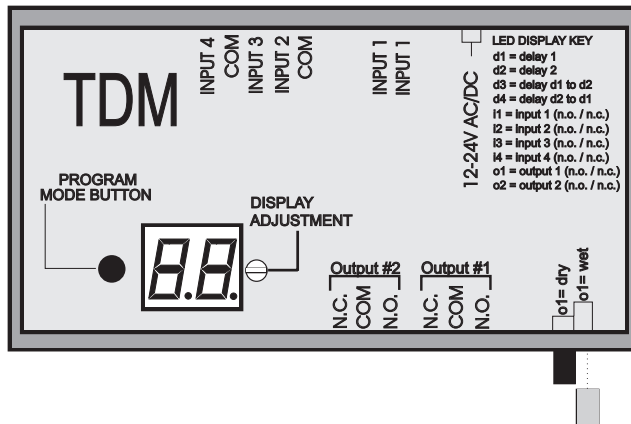

Once the TDM has been wired for the above application, programming of the device is as follows:

- 1) Apply power to the unit. The display will flash double bars (--) indicating that the unit is in its normal operating ready mode.
- 2) To begin programming, depress the **PROGRAM MODE BUTTON** one time. The first parameter to be programmed will appear on the display. This is the delay time, or "on time" of the output #1 and is displayed as **d1** followed by the time setting of **2.0** (Factory Setting) which indicates 2.0 seconds (It will flash between the two). This is the time duration that you want the interior door to remain open (It's usually set around 4-5 seconds). To adjust the time setting, use a small screwdriver and rotate the **DISPLAY ADJUSTMENT** clockwise to increase and counterclockwise to decrease the time setting. After the desired value is displayed, depress the **PROGRAM MODE BUTTON** again to save the value. The display will now read **d2**. **d2** is the delay time or "on time" of output #2. This is the time setting that you want for the exterior door to remain open. This is usually set around 4-5 seconds. To adjust the setting, rotate the **DISPLAY ADJUSTMENT** until the desired value is displayed and then depress the **PROGRAM MODE BUTTON**. The display should then read **d3**. This is the setting for the delay time between the activation of the interior door and the exterior door. This time is usually set around 1-4 seconds. Again, adjust the setting and then depress the **PROGRAM MODE BUTTON**. The display should now read **d4**. This is the delay time between the opening of the doors going in the opposite direction. Adjust this value in the same manner as before. When the **PROGRAM MODE BUTTON** is depressed, **i1** will then be displayed. Now wait 30 seconds until the double bars (--) appear, indicating that the unit is in its normal operating ready mode.
- 3) You are now ready to test your installation. If any of the time settings need to be changed, make the change and press the **PROGRAM MODE BUTTON** once to save the new value. Then wait 30 seconds until the double bars (--) appear again, indicating that the unit is in its normal operating mode.
- 4) During operation of the unit, the display will indicate its operating status. Please refer to Figure 5 at the end of this installation manual.



FIGURE 5—Operation Display & Additional Programming Options

When the unit is operating, the display will indicate which output is active for the duration of its programmed time delay. For relay output #1, a **1** will be displayed and **2** will be displayed for relay output #2. If the delays d3 or d4 are used (such as an installation using a Mag Lock or a Vestibule application), the delay will be evident between the displaying of both outputs.

In addition to the settings already described in the previous sections, below is a listing of various options which are programmable on the TDM. The LED display vs. function are as follows:

- = Ready Mode (flashing)
- d1** = Time Delay or "ON TIME" of relay output #1—0.0 to 99 seconds
- d2** = Time Delay or "ON TIME" of relay output #2—0.0 to 99 seconds
- d3** = Time Delay between d1 and d2—0.0 to 99 seconds
- d4** = Time Delay between d2 and d1—0.0 to 99 seconds
- i1** = Switch Input #1—(N.O. or N.C.)
- i2** = Switch Input #2—(N.O. or N.C.)
- i3** = Switch Input #3—(N.O. or N.C.)
- i4** = Switch Input #4—(N.O. or N.C.)
- o1** = Relay Output #1—(N.O. or N.C.)
- o2** = Relay Output #2—(N.O. or N.C.)
- - = Error (flashing)

The **PUSHBUTTON FAULT INDICATOR** is a special feature designed to alert the installer if a pushbutton is "stuck" in the active position or if the wires have shorted. If this occurs, the display will flash double dots (. .). Additionally, this could mean that the wiring did not match the programmed parameter. In other words, the unit may be programmed for use with a normally open switch, but may be wired to a normally closed switch. Normal operation will resume once the fault condition has been cleared.

WET/DRY CONTACT OPTION:

The TDM has the option of supplying power to relay output #1 contacts. This is known as "WET" contacts instead of the conventional "DRY" contacts or simple contact closure. Providing this voltage can simplify the wiring of installations where an Electric Locking device is used. However, the voltage supplied to the output is the same voltage supplied to the input of the TDM and must be compatible with the Locking device to be controlled. Please contact the factory for additional information.