



DH98i Industrial Door Motion & Presence Detector

SENSORS & SWITCHES



Product Name

DH98i Industrial Door Motion & Presence Detector

Manufacturer

MS Sedco
8701 Castle Park Drive
Indianapolis, IN 46256
Phone: (800) 842-2545
(317) 842-2545
Fax: (800) 849-3387
(317) 849-3387

Email: custsvc@mssedco.com
www.mssedco.com

Product Description

BASIC USE

The DH98i is a combination 2-row motion, 2-row presence sensor designed to provide both activation and presence detection for automatic industrial doors in a single device that can be mounted up to 13 feet (4m) high.

The DH98i is based on the most reliable active infrared technology available—Floor Reflection Method (FRM). With FRM up to 48 individual detection zones are precisely reflected off of the floor in a rectangular pattern for unparalleled performance.

The DH98i provides motion detection as far as 10 feet (3m) from the door while providing a dense zone of presence detection

in close to the door. With a sensing area made up of 48 detection zones, the DH98i provides the highest density of any of our infrared detectors for industrial applications.

Width and depth are both mechanically adjustable. In addition, depth can be altered electronically. Other electronic adjustments such as 4 presence timer settings, 4 frequency settings and interior/exterior modes are available without the use of proprietary set-up devices.

Technical Data

- Floor Reflection Method (FRM) Active Infrared Technology
• One Sensor Covers Any Safety Zone Application (Fast-Roll or Industrial Doors)
• Up To 48 Detection Zones
• Mount Up To 13' (4m) High
• 10 Mechanical Width Settings From 36" To 20'
• Electronic Depth Adjustment From 1 to 4 Rows (Also 5 Tilt Settings)
• Quick-Connect Wiring (Harness Included)
• Four Presence Timer Settings Up To Infinity And Four Frequency Settings
• 12V to 24V AC or DC Operation
• Form C Dry Relay Contact (N.O., COM, N.C.)

SPECIFICATIONS

Table with 2 columns: Specification Name, Value. Includes Model (DH98i), Detection Method (Floor Reflection Method (FRM) Active Infrared), and Max. Installation Height (13.2 Feet (4m)).

Sensitivity Adjustment
Variable (via potentiometer)

Detection Area Adjustment
Pattern Width (36" to 20')
Pattern Depth (1 to 4 Rows + tilt settings of 0° to 10° in 5 steps)

Detection Beams
12 Beams x 4 Rows = 48 Beams

Presence Detection
1 & 2 Rows (Door Side) Utilizing Presence Timer

Motion Detection
3 & 4 Rows (Approach Side)

Power Requirements
12V to 24V AC or DC ± 10%

Power Consumption
AC24V-3VA, AC12V-3VA
DC24V-75mA, DC12V-120mA

Output Contact
Form C Relay: DC50V 0.1A Resistor Load

Output Holding Time
Approx. 0.5 Seconds

Presence Timer (Rows 1 & 2 Only)
2 Seconds, 60 Seconds, 10 Minutes and Infinite

Operation Indication
Red LED = Detection
Green LED = Monitoring Area
Orange LED = Abnormal Oscillating between Red/Green=Fault

Enclosure Rating
IP54 (IEC60529)

Temperature Range
-4° F to 140° F (-20° C to 60° C)

Weight
Approx. 0.8 lbs. (0.35 kg)

Cover Color
Black

Accessories
Cable: 5 ft. (1.5m)

DH98i Industrial Door Motion & Presence Detector

SENSORS & SWITCHES

DIMENSIONS

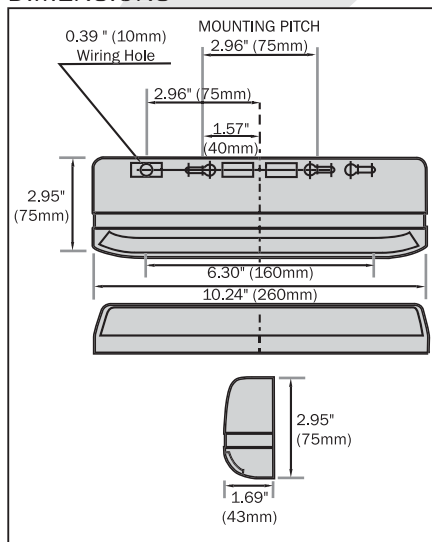

APPLICABLE STANDARDS

Enclosure Rating IP54 (IEC60529)

APPROVALS

CE

Installation

SETUP AND ADJUSTMENT

The DH98i installs easily. Simple amp connectors make wiring fast. Twin revolving lens units allow pattern width to be adjusted from wide to narrow and the body of the sensor can be tilted to adjust pattern depth. The indicator LED is clearly visible with the cover on. An 8 position dip switch allows the installer to adjust the presence timer, pattern depth, frequency, monitoring modes.

COVERAGE PATTERN

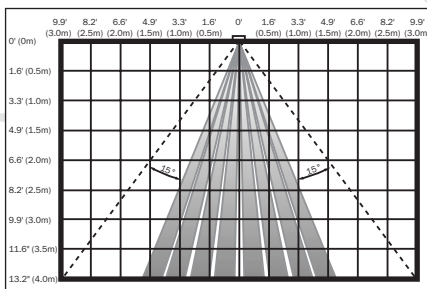

Wide Pattern @ Maximum
20' (6m) Wide

Narrow Pattern @ Maximum
10' (3m) Wide

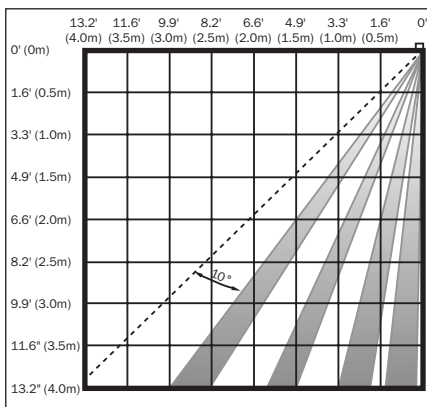

Wide Pattern @ Maximum
13' (4m) Deep

Narrow Pattern @ Maximum
13' (4m) Deep

(These detection patterns are approximate and will vary slightly. Walk-test the unit to assure the pattern desired.)

Availability & Cost

AVAILABILITY

Available internationally from manufacturer's authorized distributors; contact MS Sedco for the location of nearest distributor.

COST

Cost information on MS Sedco products is available from the manufacturer's authorized distributors.

Warranty

A one year warranty is available from the manufacturer covering defects in materials and workmanship. Contact MS Sedco for details.

Maintenance

MS Sedco recommends that all maintenance and adjustments be performed by a qualified technician.

Technical Services

MS Sedco's staff of factory trained sales and service personnel offer design assistance and technical support. Local distributors are also available to assist in selecting appropriate devices for specific uses and to provide onsite installation.

Filing Systems

- Sweet's
- Additional product information is available from the manufacturer upon request.